

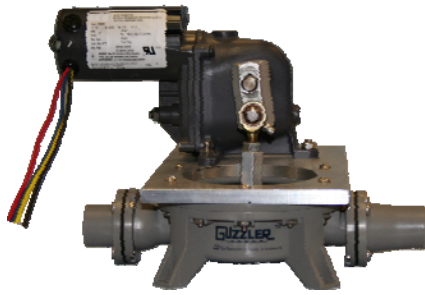

## Guzzler® 115 VAC Electric Pump GE-0400D



- 1.8 GPM — 11.0 GPM
- 115 VAC Motors from 16 to 100 RPM
- Durable, lightweight Delrin® plastic
- Accommodates 1/2" - 1-1/4" hose
- Available with wide variety of hose connections
- Optional variable speed control

### Specifications / Options

<b>Body &amp; Ports *</b>	Delrin / Gray
<b>Clamp Ring</b>	Aluminum Motor Mounting Plate
<b>Valves *</b>	Flapper, Duckbill, Umbrella
<b>Diaphragm *</b>	Buna-N, Buna-N Double Sided, Neoprene, Viton, EPDM, Silicone
<b>Clevis/Button Assembly *</b>	SS Washer + Aluminum Clevis
<b>Motor</b>	115VAC: 16 RPM, 27 RPM, 62 RPM, 100 RPM
<b>Other</b>	Variable Speed Control

\* in contact with fluid

### Available 115 VAC Motors & Performance

Pump Flow Rate <sup>3</sup> (GPM)	Motor Speed <sup>3</sup> (Name-plate RPM)	Full Load Torque (In-Lbs.)	Input HP	Full Load Amps	Max Pressure (psi)	Max Lift <sup>4</sup> (ft)	Max Head (ft)
1.8	16	110	1/15	1.4	8	18	18
3.0	27	100	1/15	1.4	7	16	16
6.8	62	45	1/15	1.4	3	7	7
11.0	100	27	1/15	1.4	2	5	5

<sup>3</sup> at 0 lift, 0 head

<sup>4</sup> Check valve recommended for lifts above 12 ft.

### Performance

<b>Flow Rate</b>	per stroke: 0.44 Qt (0.42L)
<b>Max Lift</b>	18 ft (5.5 m) <sup>1,2</sup>
<b>Max Head</b>	18 ft (5.5 m) <sup>1</sup>
<b>Max Pressure</b>	8 psi (0.6 bar) <sup>1</sup>
<b>Max Service Temp</b>	150°F (66°C)

<sup>1</sup> depending on choice of motor

<sup>2</sup> with a check valve

### Available Ports

	in	1/2	3/4	1	1-1/8	1-1/4
	cm	1.27	1.91	2.54	2.86	3.18
<b>Hose (Smooth)</b>			•	S	•	•
<b>NPT Female (Tapped)</b>		•	•			
<b>NPT Male (Threaded)</b>			•	•		
<b>Male Garden Hose (Threaded)</b>			•			
<b>Barbed</b>			•		•	
<b>Female Garden Hose Adapter</b>			•			

S Standard • Optional

### Pump Performance Curves

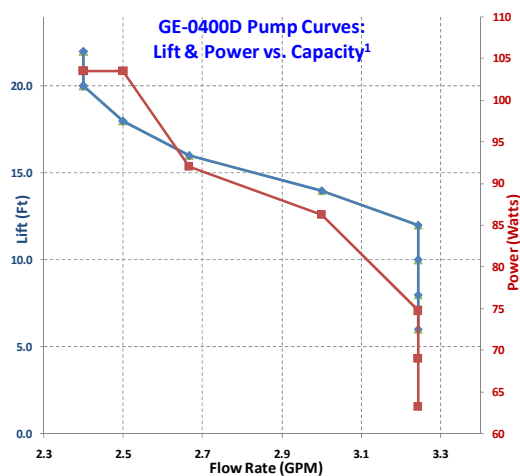

<sup>1</sup> GE-0400D Tests done with 27 RPM motor, flapper valves in pump and CV-0400D check valve at source.

### Valve Options

- Flapper** — General purpose liquid transfer.
- Duckbill** — For dirty liquid and sewage. Permits mounting in any position.
- Umbrella** — Most efficient for pumping clean liquid. Also used for air and vacuum service.

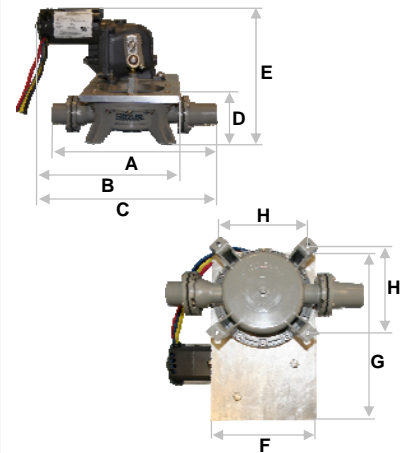

	in	cm
<b>A</b>	10-1/4	26.0
<b>B</b>	9-1/4	23.5
<b>C</b>	12	30.5
<b>D</b>	2-1/2	6.4
<b>E</b>	7-5/8	19.4
<b>F</b>	5	12.7
<b>G</b>	8-1/4	21.0
<b>H</b>	4-5/16	11.0
<b>Mounting Holes</b>	1/4	0.64
<b>Bolt Circle Diam.</b>	6-1/8	15.6
<b>Weight</b>	8.30 lb	3.76 kg

# Guzzler® 115 VAC Electric Pump GE-0400D



## Product Model Number Nomenclature Guide

### Example: GE-0400D-011-48-5050-GC

- Guzzler Electric Pump
- Model style #0400D: Delrin Body, Opposite Side Ports
- No Variable Speed control option
- Buna-N Flapper Valves
- Buna Diaphragm
- SS Washer & Aluminum Clevis
- Motor Mounting Plate Clamp Ring
- Inlet: 1" Smooth
- Outlet: 1" Smooth
- 115 VAC 27 RPM Motor

Guzzler Product	
Option	Code
Electric Pump	GE

Style (Family)	
Option	Code
Delrin, Opp. Side Ports	0400D

Speed Control	
Option	Code
None	0
Variable Speed Control	9

Valves	
Option	Code
Flapper (Buna-N)	1
Flapper (White Buna)	2
Flapper (Neoprene)	3
Flapper (Viton)	4
Flapper (EPDM)	5
Duckbill (Buna-N)	6
Umbrella (Silicone)	7

Diaphragm	
Option	Code
Buna Nitrile	1
Buna-N 3-Ply	2
Neoprene	3
Viton	4
EPDM	5
Silicone	7

**GE - 0400D - 0 1 1 - 4 8 - 50 50 - GC**

Clevis/Button Assembly	
Option	Code
SS Washer & Alum Clevis	4

Clamp Ring	
Option	Code
Motor Mounting Plate	8

Hose Connections		
Option	Code	
	Inlet	Outlet
1/2" NPT Tapped	31	31
3/4" Smooth	40	40
3/4" NPT Tapped	41	41
3/4" NPT Threaded	42	42
3/4" Barbed	43	43
3/4" Female GH Adapter	45	45
3/4" Male Garden Hose	46	46
1" Smooth	50	50
1" NPT Threaded	52	52
1-1/8" Smooth	60	60
1-1/8" Barbed	63	63
1-1/4" Smooth	70	70

115 VAC Motor		
Option (Speed / Torque)	Code	
16 rpm / 110 in-lbs	GA	
27 rpm / 100 in-lbs	GC	
62 rpm / 45 in-lbs	GL	
100 rpm / 27 in-lbs	GS	

